

Analog Digital Converter

AWA/SSI/12

12 Bit

Version 2



Digitronic Automationsanlagen GmbH

Steinbeisstraße 3 · D - 72636 Frickenhausen · Tel. (+49)7022/40590-0 · Fax -10
Auf der Langwies 1 · D - 65510 Hünstetten-Wallbach · Tel. (+49)6126/9453-0 · Fax -42
Internet: <http://www.digitronic.com> · E-Mail: mail@digitronic.com

Notification

This handbook corresponds with the unit version of 18.3.2002. The company Digitronic Automationsanlagen GmbH reserves the right to implement changes that result in an improvement of the quality and the functions of the device at any time and without any announcements.

This instructions manual was created with a maximum of care, but mistakes are not out of the question. We are thankful for any comments, regarding possible mistakes in the instruction manual.

UP-date

You can also obtain this instruction manual on the Internet at <http://www.digitronic.com> in the latest version as PDF file.

Qualified personal only

Commissioning and operation of the device may only be carried out by qualified personal. Qualified personal are persons, authorized with commissioning, grounding and labeling devices, systems and electrical circuits according to the applicable standards of security

Liability

(1) The salesperson is liable for any damages for which he or the rightful owner is responsible up to the amount of the actual salesprice. Liability concerning missed profits, failed-to-appear savings, indirect damages and consequential damage is excluded.

(2) The liability restrictions above are not valid concerning assured characteristics and damages, which are caused by intention or coarse negligence.

Protection

The device AWA/SSI/12 and this instruction manual are protected by copyright. All rights are reserved. Neither the device AWA/SSI/12, nor this document may be copied as a whole or partially, photocopied, reproduced, translated or transferred to electronic media of any kind or into machine readable format without prior written permission by the company Digitronic Automationsanlagen GmbH.

Note: The products of Digitronic are so well constructed that they will not be effected by the millenium.

Note: This device fulfills the following norms according to electromagneticalcompatibility: EN 55011, EN 55022, EN 55024 Teil 2, EN 50082 Teil 2, ENV 50140, VDE 0843 Teil 2, VDE 0843 Teil 4, VDE 0871, VDE 0875 Teil 3 ("N"), VDE 0875 Teil 11, VDE 0877 Teil 2, IEC 801 Teil 3, IEC 801 Teil 2, IEC 801 Teil 4, IEC 801 Teil 5.



(c) Copyright 1992 - 2004 / Datei: AWASSIE.DOC

Digitronic Automationsanlagen GmbH
Auf der Langwies 1
D-65510 Hünstetten - Wallbach
Tel. (+49)6126/9453-0 Fax. (+49)6126/9453-42
Internet: <http://www.digitronic.com> / E-Mail: mail@digitronic.com

Table of contents:

1. Introduction 3
 1.1. Data format at the synchronous serial interface 3
 2. Assembly 3
 3. Terminal allocation 4
 3.1. Terminal allocation of the power supply 4
 3.2. SSI interface 4
 3.3. Terminal allocation of the analog input 4
 3.4. An example for terminal allocation of the CamCon 4
 4. Configuration 4
 4.1. Change the input - signal level 4
 4.2. Reference voltage supply 5
 4.3. Calibration 5
 4.3.1. Calibration during power input 5
 4.3.2. Calibration during voltage-input 0 - +10V 5
 5. Dimensions 6
 6. Technical data 6

1. Introduction

The analog - digital - converter AWA/SSI/12 of the next generation offers the possibility to measure voltages from 0 to +10 Volt or from 0 to 20mA with a resolution of 12 Bit. The enclosed pre-resistor enables adjusting and configuring the measuring range. The measured value is read out via the serial synchronous interface.

1.1. Data format at the synchronous serial interface

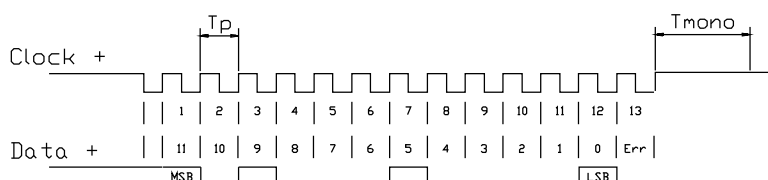

- Tp = clock impulse maximum 1MHz
minimum 100kHz
- Tmono = Monoflop time minimum 25µs
- Err = SSI Errorbit always low

Data format Graycode, according to Stegmann Tannenbaum, compatible to the singleturn encoder with 4096 steps.

2. Assembly

The device is clip-locked onto an "EN carrier rail" in the switchboard (see also chapter "5. Dimensions" on page 6). The grounding pins and cable mantlings are to be put on the shortest way possible onto serial grounding clip next to the device. The grounded assembly plate and its electrical connection to the "EN carrier rail" allow an excellent grounding of the disturbances onto the covering. All cable connections are to be switched in a cold state!! The SSI data lines of the external interface are galvanically separated with an optical coupler they have to be shielded, wired as pairs and the shield has to be laid on ground with both cable ends. Analog signals have to be placed and covered separately and the cover has to be grounded on one end. The supply voltage measures 24V DC +/- 20%.

3. Terminal allocation

3.1. Terminal allocation of the power supply

Terminal 1	0V voltage supply
Terminal 2	0V voltage supply
Terminal 3	+24V voltage supply
Terminal 4	+24V voltage supply

3.2. SSI interface

DSUB Pin 5	SSI Data	+
DSUB Pin 9	SSI Data	-
DSUB Pin 8	SSI Clock	+
DSUB Pin 3	SSI Clock	-

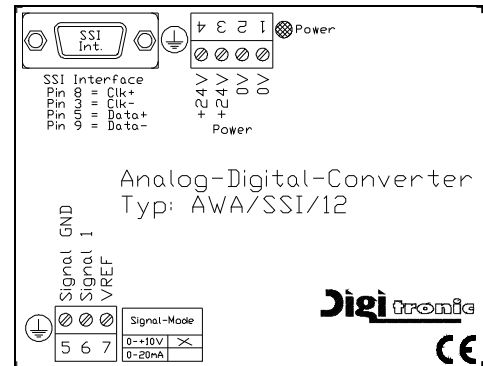

3.3. Terminal allocation of the analog input

Terminal 5	Signal ground GND
Terminal 6	Analog IN
Terminal 7	reference voltage

3.4. An example for terminal allocation of the CamCon

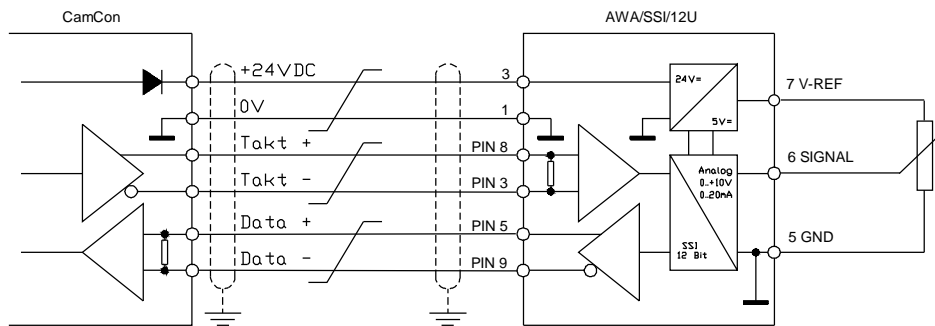

Attention: At the CamCon an SSI-singleturn encoder with 4096 steps, Gray **has to be chosen** as the measuring system at this AWA/SSI version 2.

4. Configuration

4.1. Change the input - signal level

The analog inputs' signal level can be changed by soldering bridges on the solder side of the AWA/2X12B's printed circuit board.

The following input signals can be set: "0-20mA" or "0 - +10V".

The adjusted signal level is marked for every input by with a cross on the metal cap.

To change the input level, detach all cable connections from the device., remove the device from the switch chest, open the floor part at the devices side using a screwdriver and pull the printed circuit board out of the floor part. On the soldering side of the printed circuit board are to soldering bridges for signal input 1 and 2 which are called SJ1 to SJ4. For the measuring of a currency signal the solderingbridge SJ" has to be closed. To measure a voltage signal, it has to be opened.

Note: Having adjusted the desired signal level, the input switching has to be equalized anew. See also chapter "4.3. Calibration".

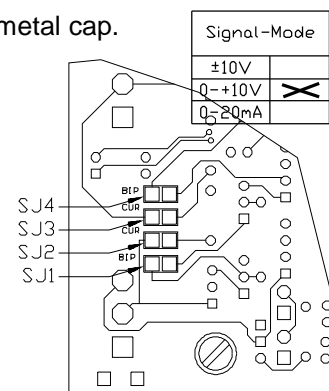

4.2. Reference voltage supply

Two intern voltages (+4.096 and +5V) are available, an external voltage source may be enabled by switching them both of. The choice is made via a jumper ledge on the component side of the printed circuit board. To change the reference voltage, remove the cap by unscrewing the four cap nuts and choose your voltage source at jumper JP1.

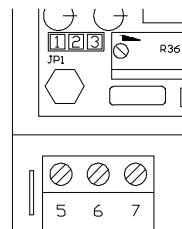

Bridge at 1+2	= +5V	Ref. voltage from the operating voltage.
Bridge at 2+3	= +4.096V	Ref. voltage by precision voltage controller (default).
Bridge open	= external	Ref. voltage external by at least +1V to a maximum of +5V.

Note: If the source of reference voltage is changed, the input switching has to be equilibrated anew. (see also chapter "4.3. Calibration").

4.3. Calibration

If the AWA/2X12B module has to be equilibrated anew, remove the case's top by unscrewing the four cap nuts, to get to the potentiometer. Four multi-gear trimmer called R36 is provided for this purpose.

4.3.1. Calibration during power input

Set a constant power source to the terminals 5 and 6. The value of currency has to be known with great accuracy. It should be in the range of 15 to 20 mA. Now choose the menu in which this value is displayed in the device (CamCon). You are able to increase this displayed value by turning to the left at the R36 (input 1) or R39 (input 2) or de-crease it by turning to the right. Set the now present current or it's corresponding value and seal the potentiometer with sealing wax.

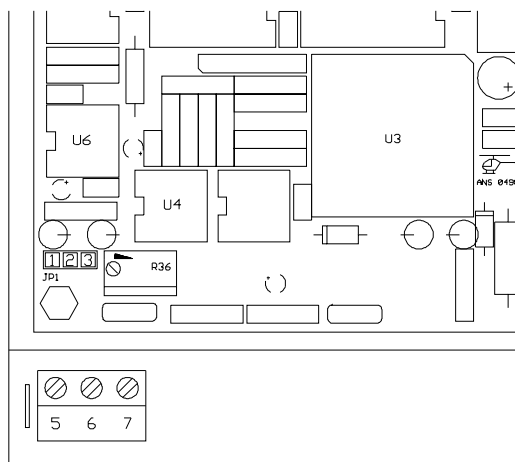

4.3.2. Calibration during voltage-input 0 - +10V

Set a voltage source to the terminals 5 and 6. The value of voltage has to be known with great accuracy. It should be in the range 0+5 to +10 Volt. Now choose the menu in which this value is displayed in the device (CamCon). You are able to increase this displayed value by turning to the left at the R36 (input 1) or R39 (input 2) or de-crease it by turning to the right. Set the now present voltage or it's corresponding value and seal the potentiometer with sealing wax.

5. Dimensions

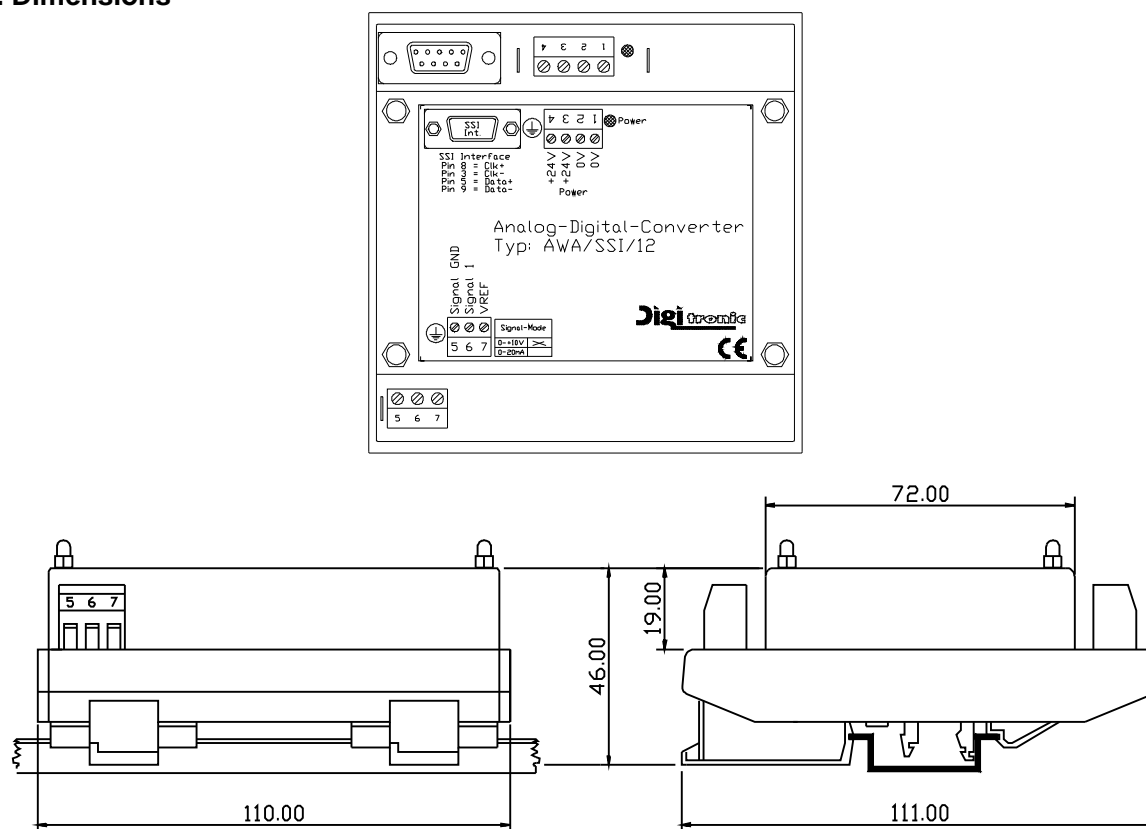

The following mounting rails may be used to assemble the case:
NS 35 / 7.5 (DIN 50022), NS 35 / 15 (DIN 50022) oder NS 32 (DIN 50035)

6. Technical data

Voltage supply:24VDC +-20%
Power consumption:150 mA
Input ranges:"0 - +10V" oder "0 - 20mA"
Input resistance:	
at voltage input:RL = 10 kOhm
at power input:RL = 220 Ohm
Resolution:12 Bit
Reference voltage source:+4.096V (standard), +5V oder external.
Data output:synchronous serial RS422, Graycode corresponding to Stegmann "Tannenbaum".
Clock frequency:maximum 1 MHz minimum 100 kHz
Monoflop i.e. transforming time:minimum 250 µs
Grounding:via 4 * 6.3mm Flatplugs directly to be laid on row- grounding pin.
Assembling:simply clamp upon carrier rail according to EN 50 022, may be set in rows. The following mounting rails may be used to fasten the case: NS 35 / 7.5 (DIN 50022) NS 35 / 15 (DIN 50022) NS 32 (DIN 50035)
Disassembly:by pulling back the snapping bars.
Protection:Type of case: Phoenix UM corresponds to IP20 and cap made of 1mm galvanized tin
Dimensions:See also chapter 5. Dimensions.
Working temperaturer:0°C ... + 50° C
Weight:approximately 400g