

# PATLITE®

New Frontiers in Safety, Security and Comfort

Improve productivity in any setting



"We used to use colored cards to alert our supervisor. But after a WSST was installed, we could alert our supervisor quicker and without interfering with the incoming call."

WSST  
Manual Control Box



"Whenever I ran out of parts, I had to stop to go look for my supervisor. Now with an HSST kit installed, I save time to alert my supervisor and not even have to leave my workstation."



HSST Series  
Manual Indicating Light

# WSST Manual Control Box



PATLITE's new WSST Control Box is the latest product that offers an exciting all-in-one functionality as well as remote operation capability to meet the growing needs of more than just the manufacturing industry.



## Applications



Emergency Operations

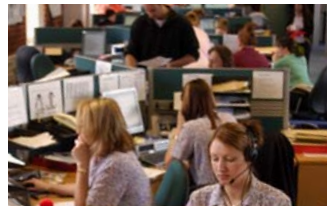

Call Centers



Applications for Safety, Security, Immigration, Customs.



Retail check stands, banks, Post office, Airport counters.

Desktop

Wall Mounting

Remote Mounting

Tower lights, cables and poles are sold separately.

## FEATURES

- Universal manual control box for PATLITE visual alert LED Signal Towers.
- Accommodates up to five LED units (Red, Yellow, Green, Blue and Clear).
- Optional sound alarm available.\*<sup>1</sup>
- Each LED unit can be manually configured for "steady on" or "flashing".\*<sup>1</sup>
- Sturdy metal construction with Six color coordinated push buttons.
- Various configurations available including all in-one (wall, desktop and remote) mounting capabilities.
- Very easy setup and operation.

\*<sup>1</sup> Must purchase Signal Towers with FB (flashing/buzzer) functionality.

# HSST Series Manual Indicating Light

The HSST kit is a low cost turn-key solution with a pre-assembled, pre-wired light tower for manual control. The kit includes a three tiered LED signal tower (standard colors of Red/ Yellow/ Green), two poles, one short (80mm) and one long (310mm), necessary mounting brackets, 120V AC adaptor (with an 1,800mm cord) and a manually operable control box.



## Applications



Lean manufacturing workstations



Remote visual indication for business offices, customer center and hospitals

Short (80mm) and long (310mm) pole with bracket included

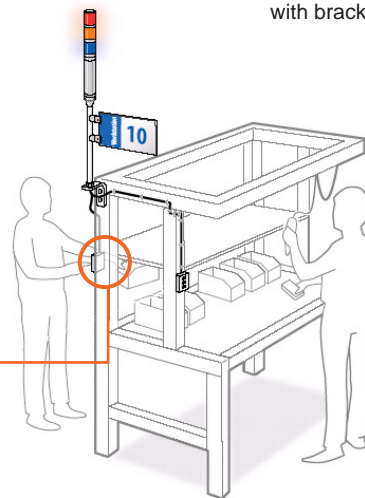

Control Box

## Easy to Use

- Call for additional parts
- Summon a supervisor



## FEATURES

- HSST standard colors: red, yellow, and green.
- LED illuminating light offers maintenance-free operation.
- 120V AC adaptor makes set-up easy in any location (UL Listed).
- Complete kit includes everything including mounting brackets that fits standard cubicle partitions.\*<sup>2</sup>
- 120V AC adaptor comes with a 1800mm cord length.
- Three button switchbox with mounting screws.

\*<sup>2</sup> Kit also includes 50mm diameter signal tower with three LED modules (red/ yellow/ green) , 1400mm cable, and 120V AC adaptor.

# Specification and Dimensions

**WSST**

**Mounting Method**

1. Wall Mounting Example  
(Without L-angle)

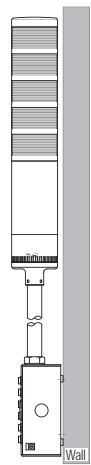

2. Wall Mounting Example  
(With L-angle)



3. For Desktop Installation



Flat surface  
(Place the WSST on a flat surface.)

4. Remote installation  
Example



**Dimensions**

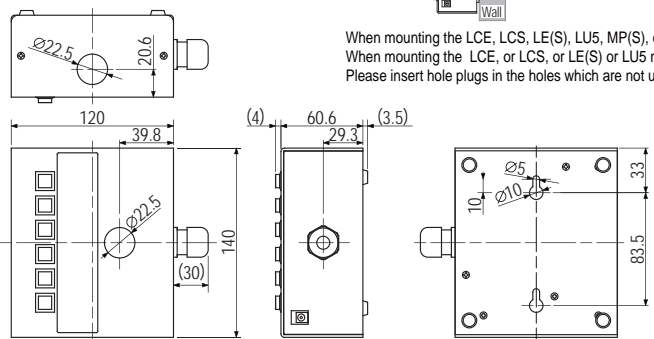

When mounting the LCE, LCS, LE(S), LU5, MP(S), or ME(S/L) with the L-angle, use SZ-013 L-angle (sold separately)  
When mounting the LCE, or LCS, or LE(S) or LU5 modules it is necessary to use the SZ-903 adaptor (sold separately) and two nuts with a thickness less than 5.5mm.  
Please insert hole plugs in the holes which are not used.

**Specifications**

|                             |   |
|-----------------------------|---|
| Rated Voltage               | 24V DC (No polarity)                                    |
| Operating Voltage           | Rated Voltage $\pm 10\%$                                |
| Operating Temperature Range | 0°C ~ 40°C  |
| Mounting Location           | Indoor use only; Flat surface or Wall without vibration |
| Protection Rating           | No Rating   |
| Mass                        | 900g $\pm 10\%$   |

Complies with RoHS directive (DIRECTIVE 2002/95/EC)

**HSST**

Short Pole

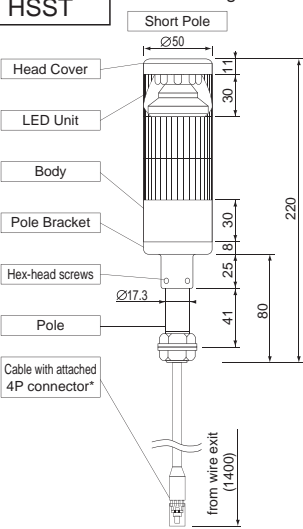

Long Pole

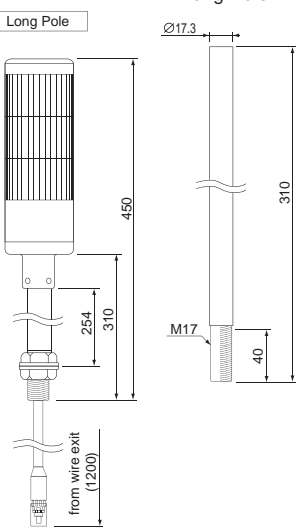

**Long Pole**

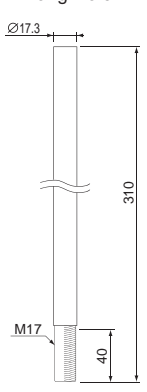

**Control Box**

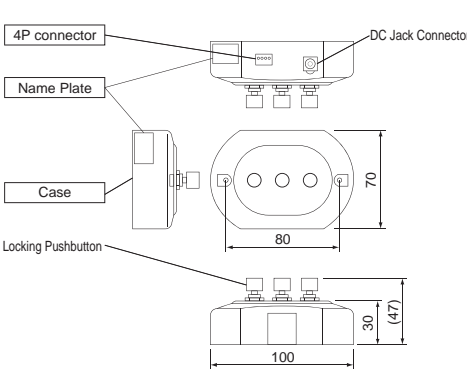

**Complete HSST-312 Kit**



**Specifications**

|                   |  |
|-------------------|--|
| Rated Voltage     | 120V AC  |
| Power Consumption | 3W (When all 3 lights are on)                      |
| Mass              | 1200g  |
| Cord Length       | AC Power : 1800mm<br>Connector Cable : 1200-1400mm |

\*Optional 3m cable extension available (sold separately) -Part number : DT-HSST-10.

**PATLITE (U.S.A.) Corporation**  
 20130 S. Western Ave., Torrance, CA 90501, U.S.A.  
 TEL. +1-310-328-3222 FAX. +1-310-328-2676  
<http://www.patlite.com/us> E-mail: sales@patlite.com

**PATLITE Europe GmbH**  
 Am Soeldnermoos 8, D-85399 Hallbergmoos, Germany  
 TEL. +49-811 9981 9770-0 FAX. +49-811 9981 9770-9 E-mail: info@patlite.eu

**PATLITE Corporation**  
 8-8, Matsuyamachi, Chuo-ku, Osaka, Japan 542-0067  
 TEL. +81-6-6763-8220 FAX. +81-6-6763-8221  
 International Division, Sales and Marketing Department E-mail: overseas@patlite.co.jp

**PATLITE (SINGAPORE) PTE LTD**  
 No.2 Leng Kee Road, #05-01 Thye Hong Centre, Singapore 159086  
 TEL: +65-6226-1111 FAX: +65-6324-1411 E-mail: sales@patlite.com.sg

**PATLITE (CHINA) Corporation**  
 Room 512, Jufeng Business Building, No.697-3 Lingshi Road, Shanghai China 200072  
 TEL: +86-21-6630-8969 FAX: +86-21-6630-8938 E-mail: sales@patlite.cn

**CAUTION** To ensure correct use of these products, read the "Instruction Manual" prior to use. Failure to follow all safeguards can result in fire, electric shock, or other accidents. Specifications are subject to change without notice.

PATLITE Corporation reserves the right to modify product specifications without prior notice within our policy of continual product development.



2 rue René Laennec 51500 Taissy France E-mail: hvssystem@hvssystem.com  
 Fax: 03 26 85 19 08, Tel : 03 26 82 49 29 Site web : www.hvssystem.com