



SEMI-REGULATED POWER SUPPLY

- Alternative or Replacement for AC Transformer
- Three Phase Input – DC Output
- DIN-Rail Mountable
- Width only 96mm
- 96% Efficiency
- 125% Peak Power Capability
- No Input Inrush Current
- Active Input Transient Blocker
- Full Power Between -25°C and +60°C
- Easy Failure Diagnostics
- No Electrolytic Capacitors on Input Side
- Cost Effective and Robust
- 3 Year Warranty

1. GENERAL DESCRIPTION

The power supplies in the Dimension X-Series include a new and innovative concept for generating an isolated DC voltage from a three-phase mains system.

A semi-regulated resonant converter enables a very compact design, maximum efficiency and extremely competitive pricing with only a small compromise in the output voltage regulation, output ripple and hold-up time.

Weighing just 1.4 kg, the device provides 960 watts of continuous output power and an additional 25% power reserve for dynamic loads. The light-weight design along with compact dimensions facilitate straightforward mounting on DIN-rail.

Primary use are applications involving supplies to motors, valves and other load circuits with a high power consumption, where an accurate output voltage regulation which is standard on traditional switched-mode power supplies is not required. Furthermore, these switched-mode power supplies can often replace mains transformers with rectifiers.

2. SHORT-FORM DATA

Output voltage	DC 48V	
Adjustment range	none	
Output current	20A	continuous
	25A	for typ. 15s
Output power	960W	continuous
	1200W	for typ. 15s
Output ripple	< 2500mVpp	20Hz-2kHz
	< 300mVpp	2kHz to 20MHz
Input voltage	3AC 400V	XT40.481
	3AC 480V	XT40.482
Mains frequency	50-60Hz	±6%
AC Input current	1.65A / phase	XT40.481, 3x400V
	1.4A / phase	XT40.482, 3x480V
Power factor	0.93	48V, 20A
AC Inrush current	typ. 2A peak	
Efficiency	96.0%	
Losses	40.0W	
Temperature range	-25°C to +70°C	operational
Derating	24W/°C	+60 to +70°C
Dimensions	96x124x159mm	WxHxD

3. ORDER NUMBERS

Power Supply	XT40.481	400V Input
	XT40.482	480V Input
Accessory	UF20.481	48V Buffer Unit

4. MARKINGS



INDEX PAGE

1. General Description	1
2. Short-form Data	1
3. Order Numbers.....	1
4. Markings.....	1
5. AC-Input.....	3
6. Input Inrush Current	4
7. Output	5
8. Hold-up Time.....	6
9. Efficiency and Power Losses.....	7
10. Functional Diagram.....	8
11. Front Side and User Elements.....	8
12. Terminals and Wiring.....	9
13. Reliability.....	9
14. EMC.....	10
15. Environment.....	11
16. Protection Features	12
17. Safety	12
18. Dielectric Strength	12
19. Approvals.....	13
20. Fulfilled Standards	13

INDEX PAGE

21. Used Substances	13
22. Physical Dimensions and Weight	14
23. Installation and Operation Instructions	14
24. Accessories	15
25. Comparison between the XT40, a Transformer and a Traditional Switched-mode Power Supply ..	15
26. Application Notes.....	16
26.1. Periodical Peak Power Capability	16
26.2. Charging of Batteries.....	16
26.3. Output Circuit Breakers	17
26.4. External Input Protection.....	18
26.5. Back-feeding Loads	18
26.6. Parallel Use to Increase Output Power ..	18
26.7. Parallel Use for Redundancy.....	18
26.8. Series Operation.....	19
26.9. Inductive and Capacitive Loads	19
26.10. Loss of One Input Phase.....	19
26.11. Use in a Tightly Sealed Enclosure	19
26.12. Mounting Orientations.....	20

INTENDED USE

The power supply shall only be installed and put into operation by qualified personnel.

This power supply is designed for installation in an enclosure and is intended for the general use, such as in industrial control, office, communication, and instrumentation equipment. Do not use this device in aircraft, trains and nuclear equipment, where malfunctioning of the power supply may cause severe personal injury or threaten human life.

TERMINOLOGY AND ABBREVIATIONS

PE and \oplus symbol	PE is the abbreviation for Protective Earth and has the same meaning as the symbol \oplus .
Earth, Ground	This document uses the term "earth" which is the same as the U.S. term "ground".
T.b.d.	To be defined, value or description will follow later.
3AC 400V	A figure displayed with the AC or DC before the value represents a nominal voltage with standard tolerances (usually $\pm 15\%$) included. 3AC means three phase input. E.g.: DC 12V describes a 12V battery disregarding whether it is charged (13.7V) or discharged (10V) As long as otherwise stated, 3AC 400V parameters are valid at 50Hz and 3AC 480V parameters are valid at 60Hz mains frequency.
3x 400Vac	A figure with the unit (Vac) at the end is a value which is used during testing without any additional tolerances included. 3x 400Vac means a three phase input.

DISCLAIMER

The information presented in this document is believed to be accurate and reliable and may change without notice.

5. AC-INPUT

		XT40.481	XT40.482	
AC input	nom.	3AC 400V	3AC 480V	
Mains arrangement		TN-, TT- or IT-Mains		consult factory if one phase is earthed
AC input range	min.	3x 360-440Vac	3x 432-528Vac	fully regulated output ($\pm 2\%$), $P_{out} > 48W$ permanently allowed, see Fig. 5-1 for output voltage regulation Absolute maximum input voltage with no damage to the power supply. Output might be off at this level.
	min.	3x 300-460Vac *)	3x 360-552Vac *)	
	max.	3x 475Vac	3x 565Vac	
Input frequency	nom.	50 – 60Hz	50 – 60Hz	$\pm 6\%$
Turn-on voltage	typ.	3x 325Vac	3x 390Vac	see Fig. 5-2
Shut-down voltage	typ.	3x 295Vac	3x 355Vac	see Fig. 5-2
Input current	nom.	1.65A	1.4A	at 20A, symmetrical input, see Fig. 5-4
Power factor (**)	typ.	0.93	0.93	at 20A, symmetrical input, see Fig. 5-5
Turn-on overshoot	typ.	1000mV	1000mV	see Fig. 5-3
Start-up delay (***)	typ.	400ms	350ms	over the entire load range, see Fig. 5-3
Rise time	typ.	40ms	40ms	0mF, 20A, see Fig. 5-3
	typ.	70ms	70ms	20mF, 20A, see Fig. 5-3

*) A minimum voltage of 3x340Vac (XT40.481) or 3x408Vac (XT40.482) is required to turn the power supply on.

**) The power factor is the ratio of the true (or real) power to the apparent power in an AC circuit.

***) The start-up delay for mains voltage interruptions up to 350ms is close to zero. In such cases, the power supply will immediately generate the output voltage once the mains voltage interruption is over. Do not use the buffer module UF20.481 as an accessory when longer mains interruptions need to be bridged (see chapter 24).

Input Voltage Range

Changes of the input voltage will be fully regulated within certain limits. The output voltage will only start to change proportionally to the input voltage with extreme under or over-voltages. The yellow LED reports an input voltage problem if exceeded by a window of $\pm 15\%$. The maximum increase of the output voltage is limited to the 57.2V OVP level. This level will be kept regulated for 2s before the power supply will shut down and reports "Shut-down" by the red LED.

Fig. 5-1 Output voltage vs. input voltage and input current

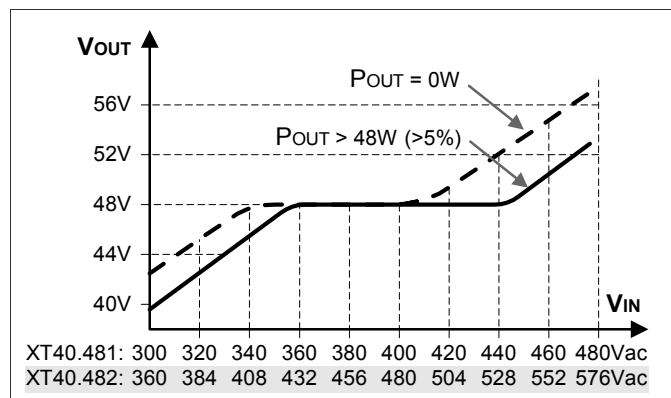

Fig. 5-2 **Input voltage range**

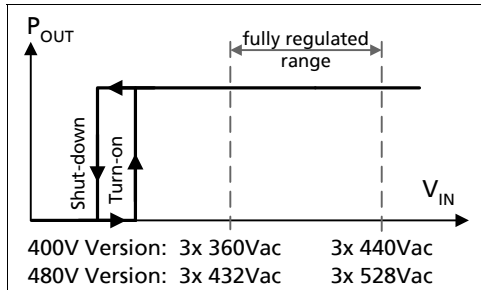

Fig. 5-3 **Turn-on behavior definitions**

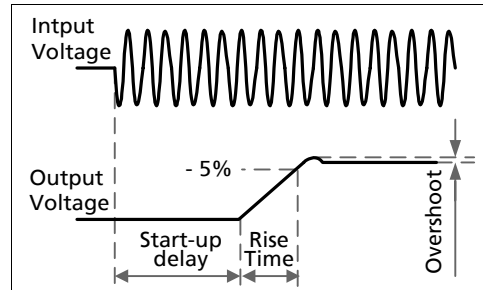

Fig. 5-4 **Input current vs. output load**

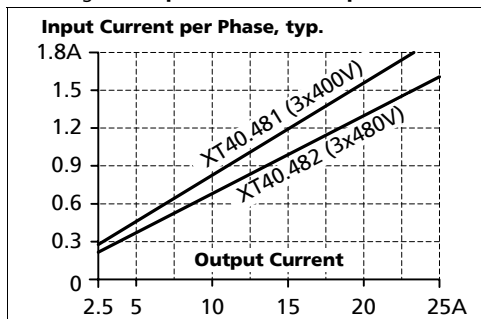
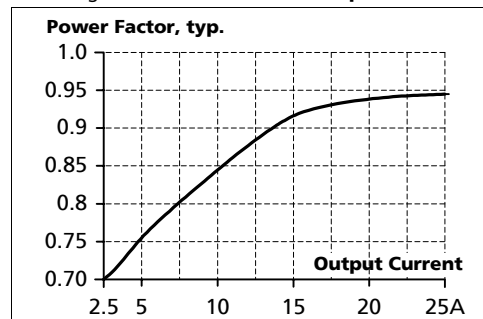

Fig. 5-5 **Power factor vs. output load**



6. INPUT INRUSH CURRENT

There is virtually no input inrush current surge as there are no electrolytic bulk-capacitors utilized on the input side of the power supply.

The charging current into the EMI suppression capacitors is disregarded for the first millisecond after switch-on.

		XT40.481	XT40.482	
Inrush current	max.	4A _{peak}	4A _{peak}	-25°C to +70°C, see Fig. 6-1
Inrush energy	max.	5A ² s	5A ² s	-25°C to +70°C, see Fig. 6-1
Inrush delay	typ.	400ms	350ms	see Fig. 6-1

Fig. 6-1 **Input inrush current, typical behavior**

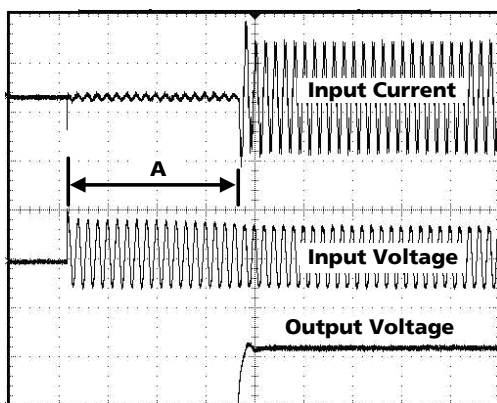

A: Inrush delay

XT40.481:

Input: 3x400Vac, only one phase shown
Output: 48V, 20A
Ambient: 25°C

Upper curve: Input current 2A / DIV
Medium curve: Input voltage 500V / DIV
(measured between L and N)

Lower curve: Output voltage 40V / DIV
Time basis: 100ms / DIV

7. OUTPUT

Output voltage	nom.	48V	
Output voltage adjustment range		none	The output voltage is fixed. No adjustment possible
Output current	nom.	20A	continuous, see Fig. 7-1
Short-circuit current		25A	up to 15s with full output voltage, see Fig. 7-1
	typ.	90A	load impedance 50mOhm, see Fig. 7-1 Note: The short-circuit current is available for 0.1s
Output power	nom.	960W	continuous
		1200W	up to 15s
Line regulation	max.	±2%	see Fig. 5-1
Load regulation	max.	1600mV	static value, 0A → 20A → 0A
	max.	100mV	static value, 2.5A → 20A → 2.5A
Ripple and noise voltage *)	max.	2500mVpp	20Hz-2kHz, 50Ohm
	max.	300mVpp	2kHz to 20MHz, 50Ohm
Output capacitance	typ.	7 600µF	

*) The ripple and noise voltage mostly consist of a mains ripple with 300Hz (50Hz mains) or 360Hz (60Hz mains). The ripple and noise voltage can be reduced by the utilization of external capacitors.

The power supply is also designed to support loads with a higher short-term current and power requirement. The short-term duration is firmware controlled by an output power manager. If the nominal output power is exceeded for a certain period of time which is defined in the zone A, B and C, the power supply responds with an automatic shut-down. Pressing the reset button or cycling the input power (10s off time is required) initiates an attempt to restart. If the fault has been cleared the device will operate normally.

The short term power can be used periodically. See chapter 26.1 for further information.

Fig. 7-1 Output voltage vs. output current, typ.

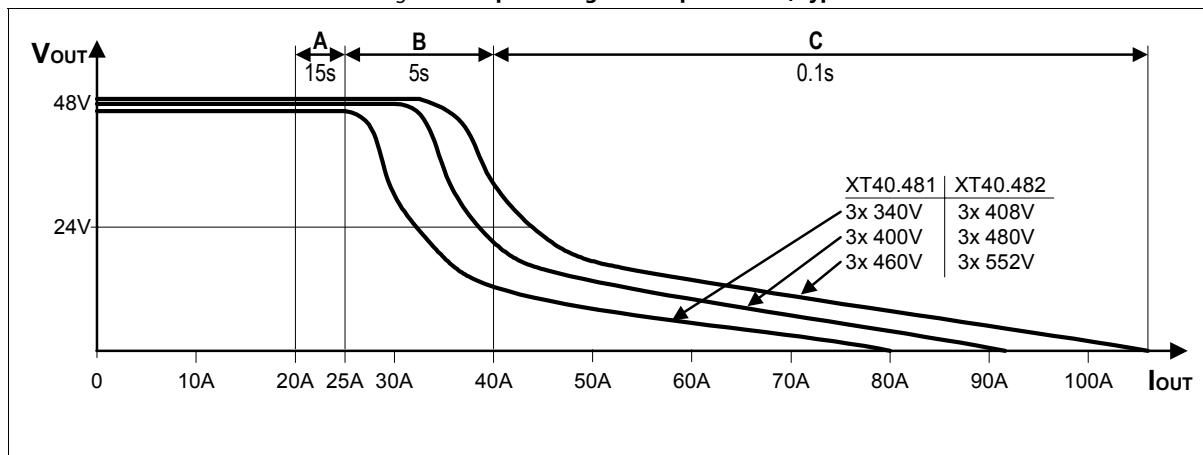

Zone A: 25% extra output power for typ. 15s

Zone B: 100% higher output current for typ. 5s

Zone C: Quick-acting shut-down after typ. 0.1s

8. HOLD-UP TIME

		XT40.481	XT40.482	
Hold-up Time	typ.	3.1ms	3.1ms	20A, resistive load, see Fig. 8-2
	typ.	2.7ms	2.7ms	20A, constant power load, see Fig. 8-2
	typ.	6.2ms	6.2ms	10A, resistive load
	typ.	5.4ms	5.4ms	10A, constant power load
Hold-up Time	min.	2.5ms	2.5ms	20A, resistive load, see Fig. 8-2
	min.	2.2ms	2.2ms	20A, constant power load, see Fig. 8-2
	min.	5.0ms	5.0ms	10A, resistive load
	min.	4.4ms	4.4ms	10A, constant power load

The energy is stored in the output capacitor. As soon as the input is turned off, the output capacitor will be discharged and the voltage will dissipate according to the curves in Fig. 8-2. The lighter the load, the longer the hold-up time. Half the load means twice the hold-up time.

The hold-up time depends on the load characteristic. The curves below show the hold-up time for a load with a resistive and a constant power characteristic.

The hold-up time is defined as the period of time when the input is turned off and until the output voltage falls below 48V ^{-15%} (40.8V). This value is defined in the IEC61131-2 as the lower limit for the supplying voltage.

Fig. 8-1 **Hold-up time, definitions**

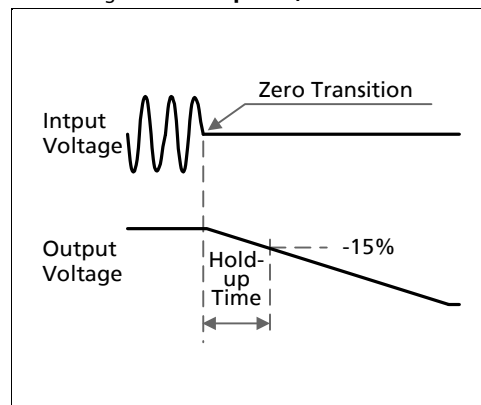
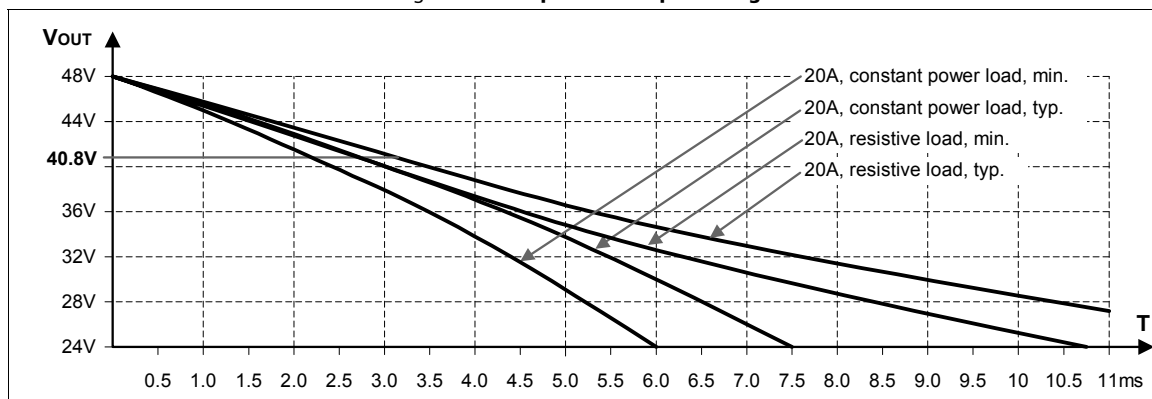

Fig. 8-2 **Hold-up time vs. input voltage**



Note: At no load, the hold-up time can be up to one minute. The green DC-ok LED is on during this time.

9. EFFICIENCY AND POWER LOSSES

		XT40.481	XT40.482	
Efficiency	typ.	96.0%	96.0%	20A
Power losses	typ.	40.0W	40.0W	20A
	typ.	18.2W	18.2W	0A

Fig. 9-1 Efficiency vs. output current

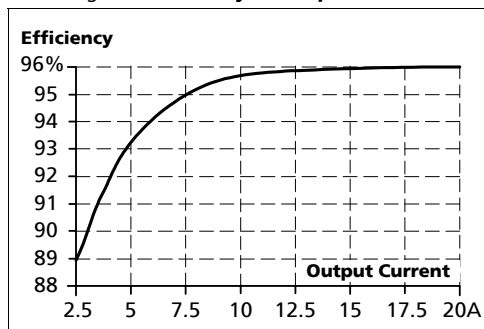

Fig. 9-2 Losses vs. output current

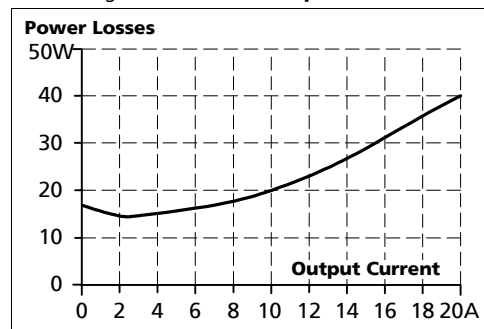

Fig. 9-3 Efficiency vs. input voltage, 48V, 20A

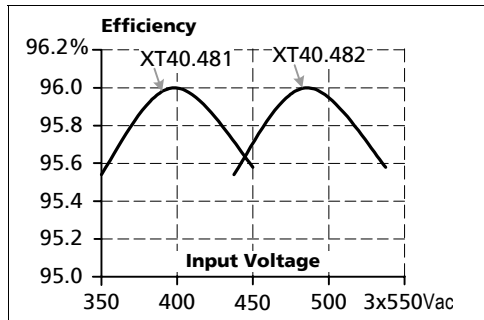
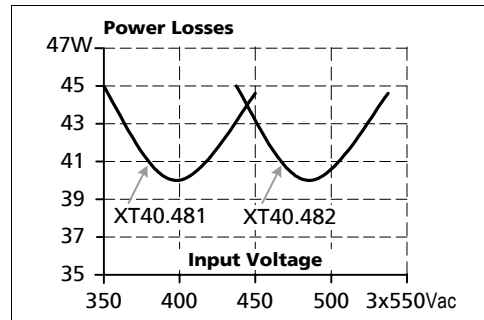

Fig. 9-4 Losses vs. input voltage, 48V, 20A



Jan. 2007 / Rev. 1.0 DS-XT40.48x-EN All parameters are specified at 48V 20A, 3x400Vac (XT40.481) or 3x480Vac (XT40.482), 25°C ambient and after a 5 minutes run-in time unless otherwise noted.

10. FUNCTIONAL DIAGRAM

Fig. 10-1 Functional diagram

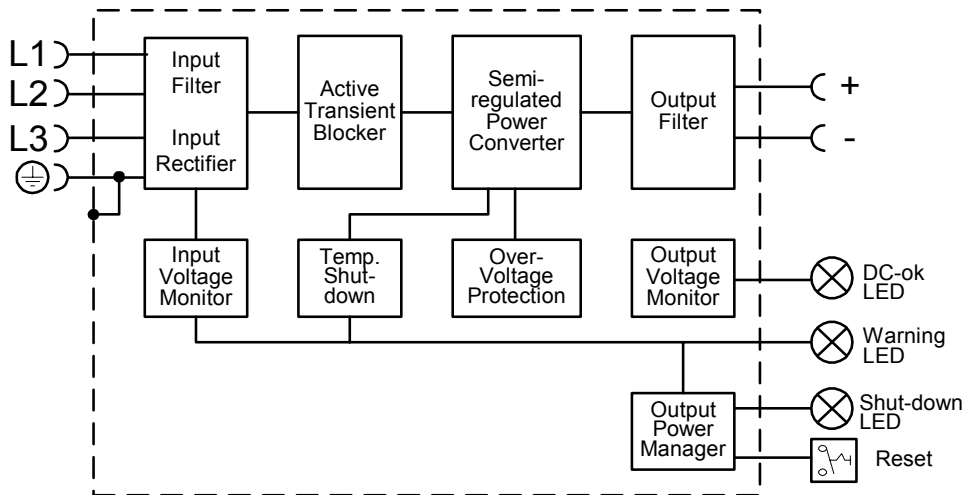

11. FRONT SIDE AND USER ELEMENTS

Fig. 11-1 Front side of XT40.481

Output Terminals
Large screw terminal

- + Positive output
- Negative (return) output

See chapter 12 "Terminals and Wiring" to choose appropriate wire size.

Input Terminals
Screw terminals

- L1, L2, L3:** Line inputs
- ⊕ PE (Protective Earth) input

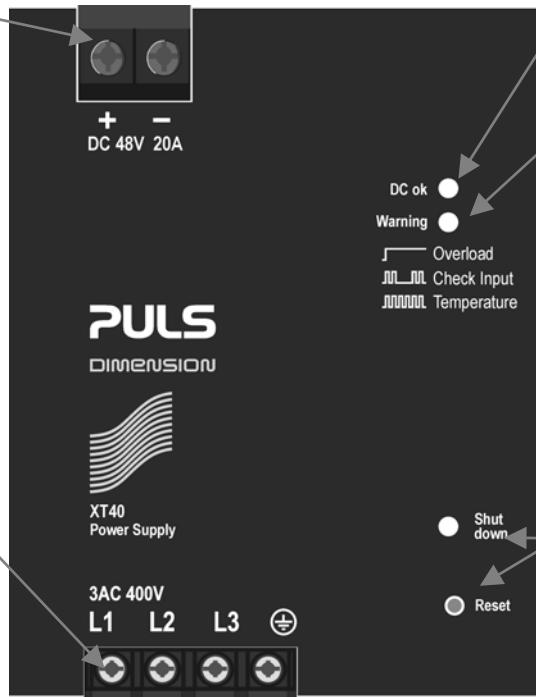

DC-ok LED (green)

Indicates a normal operation. The LED is on if the output voltage is higher than 43.2V.

Warning LED (yellow)

- A steady-state light indicates an output current higher than the nominal current and that the internal shutdown timer is running.
- A double flash indicates a phase-loss or too low / too high input voltage.
(XT40.481: < 3x333Vac or > 3x467Vac
XT40.482: < 3x400Vac or > 3x560Vac)
- A fast flash warns of an impending temperature shut-down. A shut-down can be expected within 10 minutes, if the ambient temperature or the load current stays constant.

Shut-down LED (red) and reset button

The red LED flashes when the device has shut down. Pressing the reset button or cycling the input power (10s required) initiates a restart. If the fault has been cleared the device will operate normally.

12. TERMINALS AND WIRING

Use appropriate copper cables that are designed for a minimum operating temperatures of 60°C (for ambient up to 45°C) and 75°C (for ambient up to 60°C). Follow national installation codes and regulations! Ensure that all strands of a stranded wire enter the terminal connection! Do not use the power supply without PE (Ground) connection! Up to two stranded wires with the same cross section are permitted in one connection point (except PE wire). Ferrules are allowed, but not required.

	Input	Output
Type	Screw terminal	Screw terminal
Solid wire	0.5-6mm ²	0.5-16mm ²
Stranded wire	0.5-4mm ²	0.5-10mm ²
American wire gauge	20-10 AWG	22-8 AWG
Wire stripping length	7mm / 0.26inch	12mm / 0.5inch
Recommended tightening torque	0.8Nm / 7lb.inch	1.2Nm / 10.6lb.inch

13. RELIABILITY

Lifetime expectancy	min.	77 000h	40°C, 20A
	min.	> 15 years	40°C, 10A
	min.	> 15 years	25°C, 20A
MTBF SN 29500, IEC 61709		541 000h	40°C, 20A
		978 000h	25°C, 20A
MTBF MIL HDBK 217F		199 000h	40°C, 20A, Ground Benign GB40
		267 000h	25°C, 20A, Ground Benign GB25

The **Lifetime expectancy** shown in the table above indicates the operating hours (service life) and is determined by the lifetime expectancy of the built-in electrolytic capacitors.

Lifetime expectancy is specified in operational hours and is calculated according to the capacitor's manufacturer specification. The prediction model allows a calculation of up to 15 years from date of shipment.

MTBF stands for **Mean Time Between Failure**, which is calculated according to statistical device failures, and indicates reliability of a device. It is the statistical representation of the likelihood of a unit to fail and does not necessarily represent the life of a product.

14. EMC

The power supply is suitable for applications in industrial environments as well as in residential, commercial and light industry environments without any restrictions. The CE mark is in conformance with EMC guideline 89/336/EEC and 93/68/EEC and the low-voltage directive (LVD) 73/23/EWG. A detailed EMC report is available on request.

EMC Immunity	EN 61000-6-1 and EN 61000-6-2		Generic standards	
Electrostatic discharge	EN 61000-4-2	Contact discharge	8kV	Criterion A
		Air discharge	15kV	Criterion A
Electromagnetic RF field	EN 61000-4-3	80MHz-1GHz	10V/m	Criterion A
Fast transients (Burst)	EN 61000-4-4	Input lines	4kV	Criterion A
		Output lines	2kV	Criterion A
Surge voltage on input	EN 61000-4-5	L1 → L2, L2 → L3, L1 → L3	2kV	Criterion A
		L1 / L2 / L3 → PE	4kV	Criterion A
Surge voltage on output	EN 61000-4-5	+ → -	500V	Criterion A
		+ / - → PE	500V	Criterion A
Conducted disturbance	EN 61000-4-6	0.15-80MHz	10V	Criterion A
Mains voltage dips	EN 61000-4-11	0% of 400Vac	20ms	Criterion B
		40% of 400Vac	200ms	Criterion C
		70% of 100Vac	500ms	Criterion C
		0% of 480Vac	20ms	Criterion B
		40% of 480Vac	200ms	Criterion C
		70% of 480Vac	500ms	Criterion C
Powerful transients	VDE 0160	over entire load range	1300V, 1.3ms	Criterion D

Criteria:

- A:** Power supply shows normal operation behavior within the defined limits.
- B:** During the mains voltage dip, the output voltage will decrease according to curves in the section "Hold-up Time". The unit works in normal mode once the voltage dip is over. If criteria A is required, use the buffer module UF20.481 in addition to the XT40 power supply.
- C:** Temporary loss of function is possible. Power supply might shut-down and restarts by itself. No damages or hazards for the power supply will occur.
- D:** The input transient blocker opens and the main converter is without input power during such transients. The output voltage decreases similar as described in the hold-up time section during such an event.

EMC Emission	EN 61000-6-3 and EN 61000-6-4		Generic standards	
Conducted emission	EN 55011, EN 55022, FCC Part 15, CISPR 11, CISPR 22 EN 55022		Class B, input lines	
			Class B, output lines	
Radiated emission	EN 55011, EN 55022		Class B	
Harmonic input current	EN 61000-3-2		Fulfilled, active PFC	
Voltage fluctuations, flicker	EN 61000-3-3		Fulfilled	

This device complies with FCC Part 15 rules.

Operation is subjected to the following two conditions: (1) this device may not cause harmful interference, and (2) this device must accept any interference received, including interference that may cause undesired operation.

Switching Frequency

Switching frequency	36kHz	nearly constant
---------------------	-------	-----------------

15. ENVIRONMENT

Operational temperature	-25°C to +70°C (-13°F to 158°F)	reduce output power above +60°C
Output de-rating	24W/°C	60-70°C (140°F to 158°F), see Fig. 15-1
Storage temperature	-40 to +85°C (-40°F to 185°F)	storage and transportation
Humidity	5 to 95% r.H.	no condensation allowed
Vibration sinusoidal	2-17.8Hz: ±1.6mm; 17.8-500Hz: 2g 2 hours / axis	IEC 60068-2-6
Vibration random	0.5m ² (s ³) 2 hours / axis	IEC 60068-2-64
Shock	15g 6ms, 10g 11ms 3 bumps / direction, 18 bumps in total	IEC 60068-2-27
Altitude	0 to 6000m (0 to 20 000ft)	Reduce output power or ambient temperature above 2000m sea level.
Output de-rating (for altitude)	60W/1000m or 5°C/1000m	above 2000m, see Fig. 15-2
Over-voltage category	III	EN 50178, altitudes up to 2000m
	II	Altitudes from 2000m to 6000m
Degree of pollution	2	EN 50178, non conductive

Fig. 15-1 Output current vs. ambient temp.,

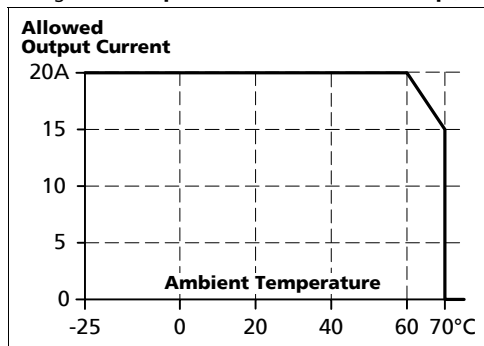
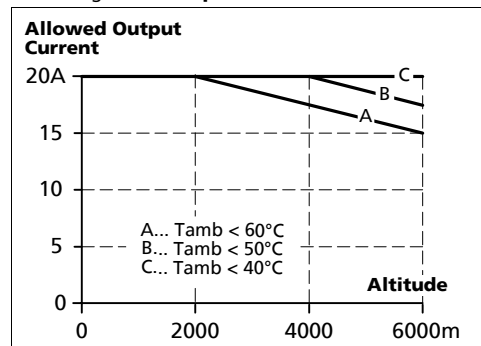

Fig. 15-2 Output current vs. altitude



The ambient temperature is defined 2cm below the unit.

16. PROTECTION FEATURES

Output protection	Electronically protected against overload, no load and short circuits *)	
Output over-voltage protection	max. 57.2Vdc	In case of an internal power supply failure, a redundant circuit limits the maximum output voltage. The output shuts-down and automatically attempts to restart.
Input overvoltage shut-down	typ. 3x 470Vac	XT40.481
	typ. 3x 560Vac	XT40.482
Degree of protection	IP 20	EN/IEC 60529
Penetration protection	> 3.5mm	e.g. screws, small parts
Over-temperature protection	yes	output shut-down, reset required
Input transient protection	MOV (Metal Oxide Varistor) and active transient blocker	
Internal input fuse	not included	See section 26.4

*) An audible noise may be heard during a no load, overload or short circuit event.

17. SAFETY

Input / output separation	SELV	IEC/EN 60950-1
	PELV	EN 60204-1, EN 50178, IEC 60364-4-41
	double or reinforced insulation	
Class of protection	I	PE (Protective Earth) connection required
Isolation resistance	> 5MOhm	input to output, 500Vdc
PE resistance	< 0.1Ohm	between housing and PE terminal
Touch current (leakage current)	typ. 0.30mA	XT40.481: 3x400V, 50Hz, TN mains
	< 0.35mA	XT40.481: 3x440V, 50Hz, TN mains
	typ. 0.40mA	XT40.482: 3x480V, 60Hz, TN mains
	< 0.45mA	XT40.482: 3x524V, 60Hz, TN mains

18. DIELECTRIC STRENGTH

Fig. 18-1 Dielectric strength

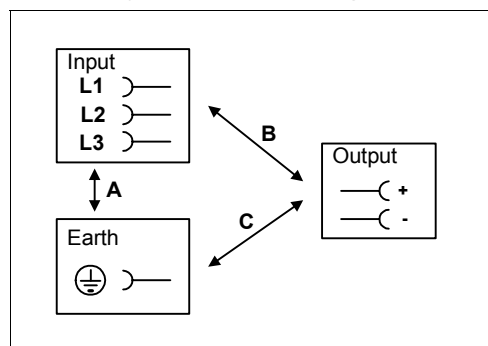

		A	B	C
Type test	60s	2500Vac	3000Vac	500Vac
Factory test	5s	2500Vac	2500Vac	500Vac
Field test	5s	2000Vac	2000Vac	500Vac

Type tests and factory tests:

Conducted by the manufacturer. Do not repeat these test in the field!

Rules for field test:

Use appropriate test equipment which applies the voltage with a slow ramp! Connect L1, L2 and L3 together as well as all output poles.

The output voltage is floating and has no ohmic connection to ground. Grounding of output allowed.

To fulfill the PELV requirements according to EN60204-1 paragraph 6.4.1, PULS recommend that either the + pole or the - pole shall be connected to the protective earth system. This helps to avoid situations in which a load starts unexpectedly or cannot be switched off when an unnoticed ground fault occurs.

19. APPROVALS

IEC 60950-1	IECEE CB SCHEME	CB Scheme, Information Technology Equipment
UL 508		LISTED for Industrial Control Equipment, E198865
UL 60950-1		RECOGNIZED E137006 recognized for the use in U.S.A. (UL 60950-1) and Canada (C22.2 No. 60950) Information Technology Equipment, Level 5

20. FULFILLED STANDARDS

EN 61558-2-17	Safety of Power Transformers
EN/IEC 60204-1	Safety of Electrical Equipment of Machines
EN/IEC 61131-2	Programmable Controllers
EN 50178, IEC 62103	Electronic Equipment for Use in Power Installations

21. USED SUBSTANCES

The unit does not release any silicone and is suitable for the use in paint shops.

Electrolytic capacitors included in this unit do not use electrolytes such as Quaternary Ammonium Salt Systems.

Plastic housings and other molded plastic materials are free of halogens.

The materials used in our production process do not include the following toxic chemicals:
Polychlorinated Biphenyl (PCB), Pentachlorophenol (PCP), Polychlorinated naphthalene (PCN), Polybrominated Biphenyl (PBB), Polybrominated Biphenyl Oxide (PBO), Polybrominated Diphenyl Ether (PBDE), Polychlorinated Diphenyl Ether (PCDE), Polybrominated Diphenyl Oxide (PBDO), Cadmium, Asbestos, Mercury, Silica

22. PHYSICAL DIMENSIONS AND WEIGHT

Weight	1400g / 3.09lb
DIN-Rail	Use 35mm DIN-rails according to EN 60715 or EN 50022 with a height of 7.5 or 15mm. The DIN-rail height must be added to the depth (157mm) to calculate the total required installation depth.

CAD files with mechanical data can be downloaded at www.pulspower.com

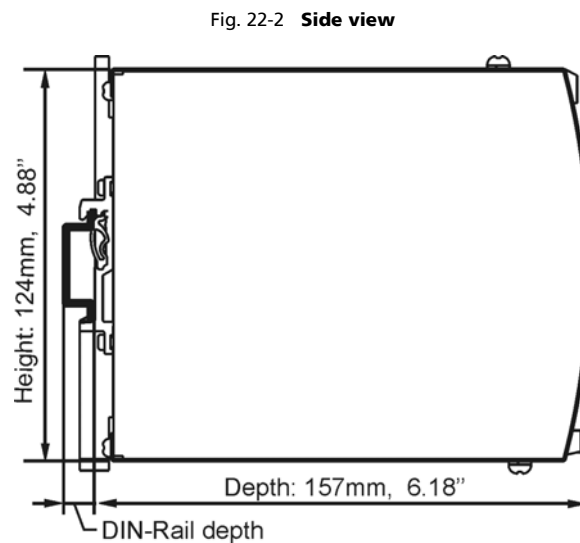
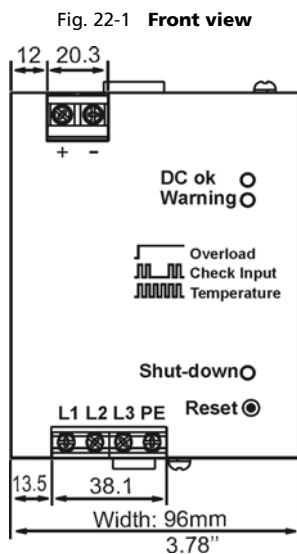

23. INSTALLATION AND OPERATION INSTRUCTIONS

Mounting and installation:

Output terminal must be located on top and input terminal on the bottom. For other orientations see section 26.12. An appropriate electrical and fire end-product enclosure needs to be considered in the end use application.

Cooling:

Convection cooled, no forced air cooling required. Do not block ventilation grill by more than 30%!

Installation clearances:

40mm on top, 20mm on the bottom, 5mm on the left and right side are recommended when loaded permanently with full power. If the adjacent device is a heat source, 15mm clearance are recommended.

Risk of electrical shock, fire, personal injury or death!

Do not use the unit without proper earth connection (Protective Earth). Use the pin on the terminal block for earth connection and not one of the screws on the housing.

Turn power off before working on the power supply. Protect against inadvertent re-powering.

Make sure the wiring is correct by following all local and national codes.

Do not open, modify or repair the unit.

Use caution to prevent any foreign objects from entering into the housing.

Do not use in wet locations or in areas where moisture or condensation can be expected

Service parts:

The unit does not contain any field replaceable parts. If damage or malfunctioning should occur, immediately turn power off and send the unit back to the factory for inspection!

24. ACCESSORIES

Buffer module UF20.481

This buffer unit is a supplementary device for DC48V power supplies. It delivers power to bridge typical mains failures or extends the hold-up time after turn-off of the AC power. In times when the power supply provides sufficient voltages, the buffer unit stores energy in integrated electrolytic capacitors. In case of mains voltage fault, this energy is released again in a regulated process.

Fig. 24-1 **Buffer module UF20.481**



Fig. 24-2 **Wiring diagram XT40 and UF20.481**

The buffer unit does not require any control wiring. It can be added in parallel to the load circuit at any given point. Buffer units can be added in parallel to increase the output ampacity or the hold-up time.

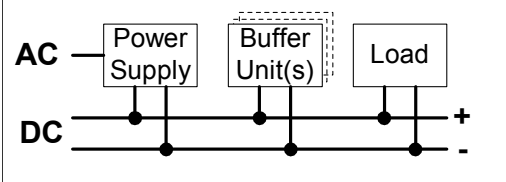

Do not use the buffer module to bridge mains interruptions which are longer than typ. 350ms. Once the mains is off for longer than typ. 350ms, the XT power supply needs an additional 1s to restart again.

25. COMPARISON BETWEEN THE XT40, A TRANSFORMER AND A TRADITIONAL SWITCHED-MODE POWER SUPPLY

	XT40 Semi-regulated power supply	Traditional switched-mode power supply	Transformer power supply
Input voltage range	+	++	-
Inrush current surge	++	+	-
Hold-up time	-	+	-
Phase-loss operation	-	+	-
Efficiency	+++	++	-
Output voltage regulation	+	++	-
Output adjustment range	-	++	-
Ripple & noise voltage	-	++	-
Error diagnostics	++	++	-
Harmonic distortion (PFC)	+	+	-
EMC	++	++	+
Ease of installation	++	++	-
Size	+++	++	-
Weight	+++	+	-
	+++...very, very good	++...very good	+...good -...poor

Jan. 2007 / Rev. 1.0 DS-XT40.48x-EN All parameters are specified at 48V 20A, 3x400Vac (XT40.481) or 3x480Vac (XT40.482), 25°C ambient and after a 5 minutes run-in time unless otherwise noted.

26. APPLICATION NOTES

26.1. PERIODICAL PEAK POWER CAPABILITY

The short term power can be used periodically.

The duration of the peak power (T_P) must be shorter than 15s.

The time between two peak power pulses must be three times longer than the duration of the preceding pulse length.

Fig. 26-Periodical peak power compatibility.

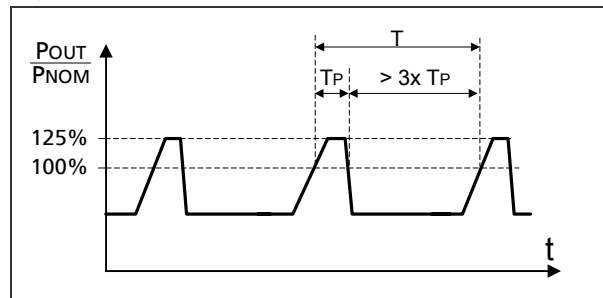

26.2. CHARGING OF BATTERIES

The power supply shall not be used to charge batteries.

26.3. OUTPUT CIRCUIT BREAKERS

Standard miniature circuit breakers (MCB's or UL 1077 supplementary breakers) can be used for branch protection but ensure, that the MCB is rated for DC voltage too. The following tests show which circuit breakers the power supply typically will trip.

Circuit breakers have huge tolerances in their tripping behavior. Therefore, these typical tests can only be used as a recommendation or for comparing two different power supplies. Furthermore, the loop impedance has a major influence on whether a breaker trips or not. Two tests were performed, representing typical situations:

Test 1: Short circuit with S1 on the power supply end of the cable (loop impedance approx. 20mOhm)

Fig. 26-1 Branch protectors, test circuit 1

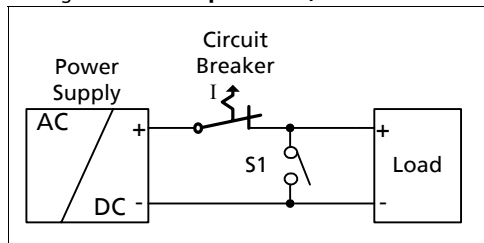

Parameters:

Input voltage: 3x400Vac, load current: 0A

The following circuit breaker tripped during the test:

- A- or Z- Characteristic:** equal or smaller 25A *)
- B- Characteristic:** equal or smaller 32A *)
- C- Characteristic:** equal or smaller 20A *)

Test 2: Short circuit with S1 on the load end (additional impedance included; represents longer load wire length).

Fig. 26-2 Branch protectors, test circuit 2

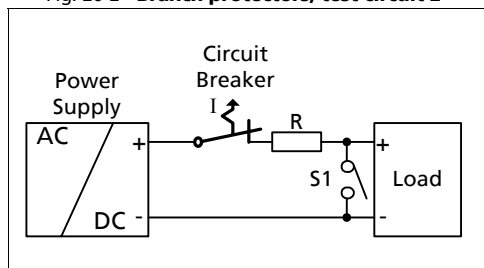

Parameters:

Input voltage: 3x400Vac, load current: 0A

The following circuit breaker tripped during the test:

- A- or Z- Characteristic:** ≤ 25A and R= 50mOhm *)
- B- Characteristic:** ≤ 32A and R= 29mOhm *)
- C- Characteristic:** ≤ 20A and R= 82mOhm *)

What does this resistance mean in wire length?

	1.0mm ²	1.5mm ²	2.5mm ²	4.0mm ²	6mm ²	10mm ²
29mOhm	1.6m	2.4m	4.0m	6.5m	9.7m	16.2m
50mOhm	2.8m	4.2m	7.0m	11.1m	16.7m	27.9m
82mOhm	4.6m	6.9m	11.4m	18.3m	27.4m	45.7m

*) A list of the circuit breakers under test is available on request.

Example:

Which wire gauge must be used at a length of 8.5m before a B-Characteristic circuit breaker with 32A will trip?

Answer: A 32A B-Characteristic circuit breaker requires a loop impedance of less than 29mOhm based on the test results. The wire length table shows that a length of 9.7m with a cross section of 6.0mm² has an impedance of 29mOhm. A wire not smaller than 6.0mm² shall be used.

26.4. EXTERNAL INPUT PROTECTION

The power supply has no internal input fuses included. The unit is tested and approved for branch circuits up to 16A (U.S.A 15A). External protection is only required if the supplying branch has an ampacity greater than this. In some countries local regulations might apply so check all local codes and requirements. If an external fuse is necessary or utilized, minimum requirements need to be considered to avoid nuisance tripping of the fuse.

		B-Characteristic	C-Characteristic
Ampacity	max.	20A	20A
	min.	6A	3A

26.5. BACK-FEEDING LOADS

Loads such as decelerating motors and inductors can feed voltage back to the power supply. This feature is also called return voltage immunity or resistance against Back- E.M.F. (Electro Magnetic Force).

This power supply is resistant and does not show adverse effects when a load feeds back voltage to the power supply. It does not matter, whether the power supply is on or off.

If the power supply is fully loaded after a return-feeding event, the output voltage can dip to 21V for approx 20ms.

The maximum allowed feed back voltage is 55.1Vdc. The absorbing energy can be calculated according to the built-in large sized output capacitor which is specified in chapter 7.

26.6. PARALLEL USE TO INCREASE OUTPUT POWER

The XT40 Series of power supplies shall not be paralleled to increase the output power.

26.7. PARALLEL USE FOR REDUNDANCY

Power supplies can be paralleled for a 1+1 redundancy to gain a higher system availability and reliability. Redundant systems require a certain amount of extra power to support the load in case one power supply unit fails. The simplest way is to put two X-Series power supplies in parallel which is called a 1+1 redundancy. In case one power supply unit fails, the other one is automatically able to support the load current without any interruption.

Please note: This simple way to build a redundant system does not cover failures such as an internal short circuit on the secondary side of the power supply. In such a condition, the shorted unit becomes a load for the other power supplies and the output voltage can not be maintained. This can be avoided by utilizing decoupling diodes which are included in the Dimension redundancy module YRM2.DIODE or YR2.DIODE. One module is needed per XT-power supply.

Recommendations for building redundant power systems:

- a) Use separate input fuses for each power supply.
- b) Monitor the individual power supply units. A DC-ok LED and a DC-ok contact is included in the redundancy module YRM2.DIODE and can report a faulty unit.

26.8. SERIES OPERATION

The power supplies of the X-Series can be put in series to increase the output voltage.

Fig. 26-3 Schematic for series operation

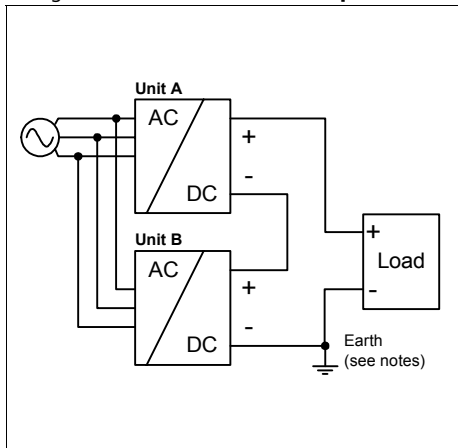

Installation notes for use in series:

- It is possible to connect as many units in series as needed, providing the sum of the output voltage does not exceed 150Vdc.
- Voltages with a potential above 60Vdc are no longer rated SELV and can be hazardous in some situations. Such voltages must be installed with a protection to make the unit touch-safe.
- For serial operation use power supplies of the same type.
- Earthing of the output is required when the sum of the output voltage is above 60Vdc.
- Keep an installation clearance of 15mm (left/right) between two power supplies and avoid installing the power supplies on top of each other.

Note: Avoid return voltage (e.g. from a decelerating motor or battery) which is applied to the output terminals.

26.9. INDUCTIVE AND CAPACITIVE LOADS

The unit is designed to supply any kind of loads, including inductive loads or capacitive loads with a capacity of up to 120mF.

26.10. LOSS OF ONE INPUT PHASE

The unit protects itself against a loss of one input phase and does not require an external protection device.

A phase-loss operation is possible for output currents below 4A. Above this level, the yellow LED indicates an impending shut-down. If the missing phase does not recover, the unit switches off after 3.5s. Pressing the reset button or cycling the input power (10s required) initiates a restart.

Please note that the input current and the output ripple are higher during the time when one phase is missing.

26.11. USE IN A TIGHTLY SEALED ENCLOSURE

When the power supply is installed in a tightly sealed enclosure, the temperature inside the enclosure will be higher than outside. The inside temperature defines the ambient temperature for the power supply.

Results from such an installation:

Power supply is placed in the middle of the box, no other heat producing equipment inside the box

Enclosure:	Rittal Typ IP66 Box PK 9519 100, plastic, 180x180x165mm
Load:	48V, 16A (=80% of the rated current); load is placed outside the box
Input:	3x400Vac
Temperature inside the box:	52.9°C (in the middle of the right side of the power supply with a distance of 2cm)
Temperature outside the box:	25.1°C
Temperature rise:	27.8K

26.12. MOUNTING ORIENTATIONS

Mounting orientations other than input terminals on the bottom and output on the top require a reduction in continuous output power or a limitation in the max. allowed ambient temperature. The amount of reduction defines the lifetime expectancy of the power supply. Therefore, two different derating curves for continuous operation can be found below:

- Curve A1** Recommended output current to achieve a minimum lifetime expectancy of 50 000h at 40°C ambient.
- Curve A2** Max allowed output current for a safe operation (results approx. in half the lifetime expectancy of A1).

Fig. 26-4
Mounting Orientation A
Standard Orientation

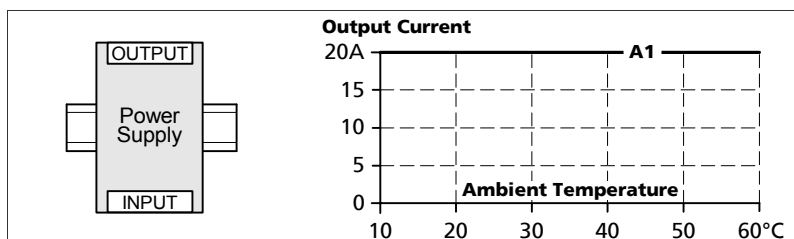

Fig. 26-5
Mounting Orientation B
(Upside down)

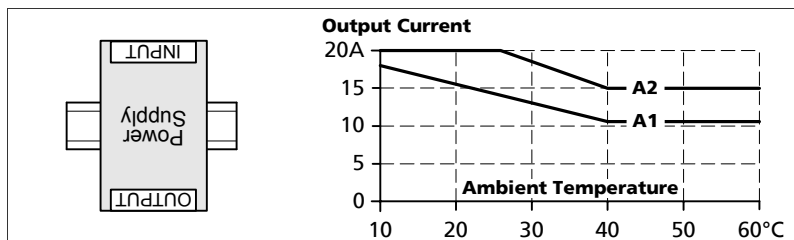

Fig. 26-6
Mounting Orientation C
(Table-top mounting)

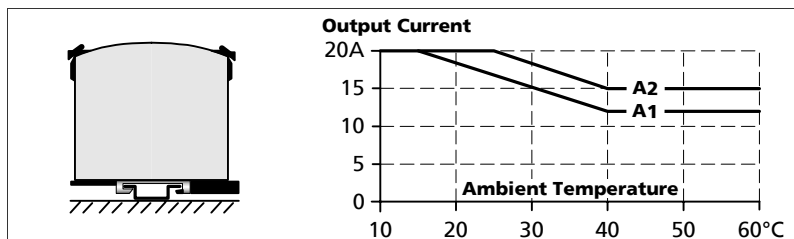

Fig. 26-7
Mounting Orientation D
(Horizontal cw)

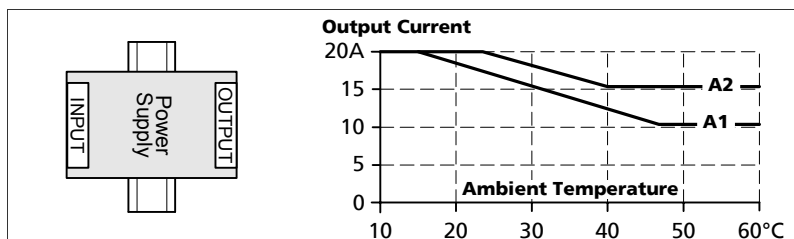
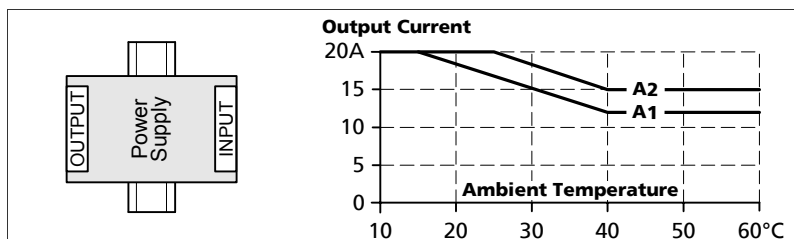

Fig. 26-8
Mounting Orientation E
(Horizontal ccw)



Jan. 2007 / Rev. 1.0 DS-XT40.48x-EN All parameters are specified at 48V 20A, 3x400Vac (XT40.481) or 3x480Vac (XT40.482), 25°C ambient and after a 5 minutes run-in time unless otherwise noted.